



FLOOR CONVECTORS

TERMO



PRACTIC
FLOOR CONVECTORS

2012

ABOUT THE COMPANY



Isan Radiátory s.r.o. is the biggest manufacturer of bathroom tubular radiators in the Czech Republic, exporting about 90 % of its production to abroad, supplying mainly the European Community markets.

ISAN trade mark represents a traditional supplier with over 50 years' experience delivering a broad range of ISAN MELODY bathroom and design radiators, ISAN EXACT radiating convectors and lamellar radiators, ISAN EXACT ECOLITE convectors with lamellar exchangers, ISAN TERMO and ISAN OPLFLEX floor convectors, ISAN ATOL column radiators and ISAN SPIRAL finned tube radiators. Top modern technological procedures and progressive thinking of the Company's staff guarantee design and technical parameters of the best quality. ISAN is a specialist for manufacturing of radiators tailored to customer's needs and wishes.

ISAN's policy is primarily focused to customer's satisfaction. Ecological processing with greatest respect to environmental protection is taken for granted. The Company has introduced and maintains Quality Management System as per the ISO 9001:2008 standard. All the heating bodies comply with certification demands according to the actual rigorous legislative standards applicable in the supplied countries. Certification procedure for territory of the Czech Republic was performed by Strojírenský zkušební ústav (Engineering Testing Institute), Brno, a notified body ES1015.



CONTENS

About the company	2
Introduction	3
Construction of floor convectors	3
Operating conditions	3
Warranty conditions	3

CROSS-FLOW FAN CONVECTION

FST20-11	4
FST40-11	5

WITH NATURAL CONVECTION

FSK20-11	6
FSK40-11	7
FSK41-11	8

Regulation of FST floor convectors	9
Regulation of FSK floor convectors	9
Accessories (thermostats, flow, valves)	10
Hydraulic resistance of heat exchangers	11
Lockshield parameters	11
Practic temperature exponents	11



INTRODUCTION



Floor convectors are mainly suitable for installation at large glassed-in panels like shop windows and are useful for heating of winter gardens, entrance halls, communication and prestige rooms, public and commercial buildings or ancient monuments. In comparison with classical heating

bodies, convectors built-in in floor channels do not occupy the room space or interfere with interior look. Using of fans with suitable speed regulation provides easy and comfortable control and ensures good flexibility and full utilization of exchanger's heating output.

CONSTRUCTION OF PRACTIC FLOOR CONVECTORS

STEEL TROUGH

Galvanized steel tank with surface finish and black spray layer inside. The tank is provided with holes for water inlet/outlet and for voltage input (type FST) and contains all function elements of convector construction. Height adjusting screws are added. The attached peripheral ledge 20×20 mm serves for covering of the installed floor convector to hide the connection elements or dilatation gaps in case of floating floor.

Al-Cu HEAT EXCHANGER

Aluminium lamellas plated on copper tube $\varnothing 16$ mm, through which the heating medium streams. Lamellas distribute heat throughout the whole exchanger area and enable the heating of room air. Air release valve and pipe union with G1/2" internal thread are standard parts of the heat exchanger.



ROLL-UP GRILL

A visual stepping grid covering the channel with installed tank. The grills are made of aluminium cross lamellas.

CROSS-FLOW FANS

Tangential fans producing forced air circulation and so enabling better utilization of exchanger heating output (FST type only). Rotors are fitted with protective coverings to prevent accidents and fan damages.

REGULATOR

Speed regulator (autotransformer) of FST convector type controls heating output as per the customer's demand. In combination with thermostat, speed regulator enables convector output control within the range of 0, 1, 2, 3.

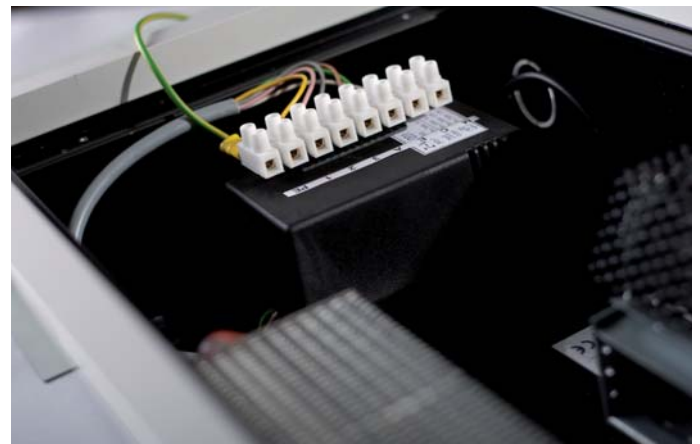

OPERATING CONDITIONS

- Hot water heating system with forced circulation
- Operating temperature of the heating medium: 110 °C as a maximum
- Operating pressure of the heating medium: 1 MPa as a maximum
- Electric components with IP20 protection, operational voltage 230 V, application in dry environment
- The convector is constructed for ambient temperature between +2 °C and 40 °C at relative humidity of 20–70%

Warning:

If there is a possibility of the ambient temperature dropping below +2 °C (e.g. rooms unheated during winter season), the heating system is to drain to avoid damage by freezing of the heating medium.

WARRANTY CONDITIONS (SHORTENED VERSION)

The Seller's warranty applies to tightness, surface finish, stated parameters of heating output and pressure losses of heating bodies professionally installed in a closed hot water system in accordance with valid standards and decrees, including corrosion properties of the heat carrying liquid, which has to be used exclusively as heating medium and never as service water.

Guarantee Period:

Guarantee period amounts to 5 years regarding joints tightness, 10 years regarding heat exchanger and 2 years regarding electric installation and galvanized steel trough.



DESCRIPTION

High-performance floor convector, suitable for heating of any room type. Recommended installation: in front of large glassed-in panels, French windows. Optimal proportion of heating output in combination with width slenderness enables universal usage for house-building.



SPECIFICATION

- House-buildings, detached houses, office buildings
- Optimal rating output
- Forced convection by tangential fans
- Smooth running
- Dry ambience

DIMENSIONS (WITHOUT LEDGE)

- Width: W = **261** mm
- Height: H = **115** mm
- Length: L = **1200, 1600, 2000, 2400, 2800** mm
- Inclusively ledge: W+35 mm, L+35 mm, H+1,5 mm
- Combination with FSK41-11, identical width

BASIC INFORMATION

- Paint coated galvanized steel trough
- Lamellar Cu-Al exchanger, connection G1/2", air release valve
- Tangential fan with rotor housing
- Anodized Al-nature roll grill
- Peripheral ledge 20 × 20 mm
- Z-VD001 regulation transformer
- Direct and corner lockshield valve packed in

INSTALLATION

Floor convectors are usually placed exchangers close to window. Recommended distance from window is 100-150 mm.

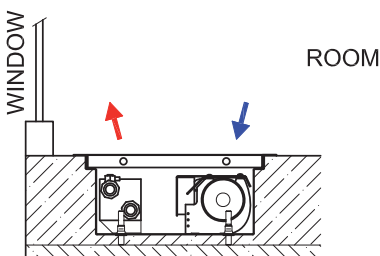

IMPORTANT INFORMATION

- Wiring diagram, see page 9
- Regulation elements, thermostats, see page 10
- Hydraulic parameters, see page 11
- Lockshield parameters, see page 11

HEATING OUTPUT

Temperature gradient	Speed	Length [mm] / Output Qn [W]				
		1200	1600	2000	2400	2800
90/70/20°C	0	108	156	205	254	302
	1	807	1209	1612	1935	2419
	2	1009	1512	2017	2420	3025
	3	1334	2002	2668	3202	4003
75/65/20°C	0	84	122	160	198	236
	1	662	992	1323	1588	1985
	2	828	1241	1655	1986	2483
	3	1095	1643	2190	2628	3285
70/55/20°C	0	67	98	128	159	189
	1	555	832	1109	1332	1664
	2	694	1041	1388	1665	2082
	3	918	1378	1836	2204	2754
55/45/20°C	0	42	61	80	99	118
	1	381	570	761	913	1141
	2	476	713	951	1142	1427
	3	629	944	1259	1511	1888

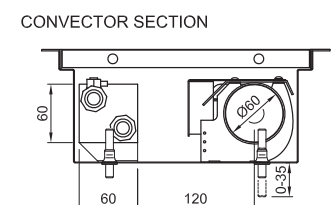
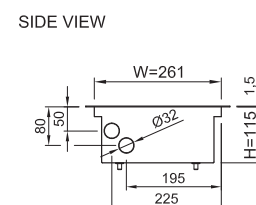
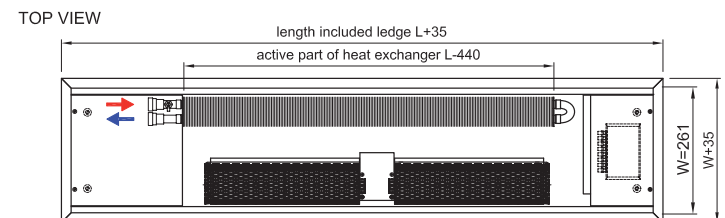
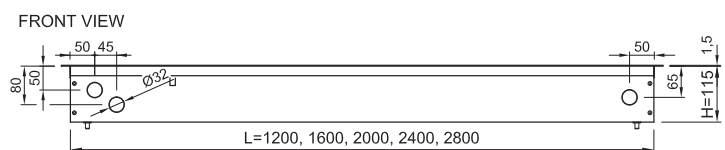



DESCRIPTION

Extremely high-performance convector, series FST, enabling covering of higher thermal losses in the room. Due to good acoustic parameters is widely used in rooms with long-time presence of persons, like offices, office buildings, flats and halls, foyers or buildings showing great thermal losses (old houses).



SPECIFICATION

- Flats, detached houses, offices, corridors
- High heating output
- Forced convection by tangential fans
- Smooth running
- Dry ambience

DIMENSIONS (WITHOUT LEDGE)

- Width: $W = 311$ mm
- Height: $H = 115$ mm
- Length: $L = 1200, 1600, 2000, 2400, 2800$ mm
- Inclusively ledge: $W+35$ mm, $L+35$ mm, $H+1,5$ mm
- Combination with FSK40-11, identical width

BASIC INFORMATION

- Paint coated galvanized steel trough
- Lamellar Cu-Al exchanger, connection G1/2", air release valve
- Tangential fan with rotor housing
- Anodized Al-natur roll grill
- Peripheral ledge 20×20 mm
- Regulation transformer, type Z-VD001
- Direct and corner lockshield valve packed in

INSTALLATION

Floor convectors are usually placed exchangers close to window. Recommended distance from window is 100-150 mm.

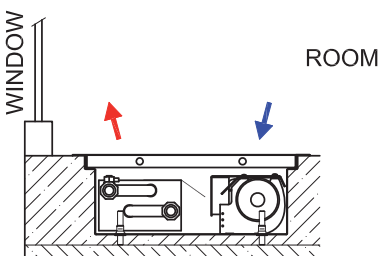

IMPORTANT INFORMATION

- Wiring diagram, see page 9
- Regulation elements, thermostats, see page 10
- Hydraulic parameters, see page 11
- Lockshield parameters, see page 11



HEATING OUTPUT

Temperature gradient	Speed	Length [mm] / Output Qn [W]				
		1200	1600	2000	2400	2800
90/70/20 °C	0	290	422	553	685	818
	1	1167	1750	2333	2800	3500
	2	1677	2514	3352	4022	5029
	3	2337	3506	4674	5608	7011
75/65/20 °C	0	223	324	425	526	628
	1	970	1455	1940	2328	2910
	2	1394	2090	2787	3344	4181
	3	1943	2915	3886	4663	5829
70/55/20 °C	0	176	256	336	416	496
	1	823	1234	1646	1975	2469
	2	1183	1773	2364	2837	3547
	3	1648	2473	3296	3956	4945
55/45/20 °C	0	107	155	203	251	300
	1	578	867	1157	1388	1735
	2	831	1246	1662	1994	2493
	3	1158	1738	2317	2780	3475

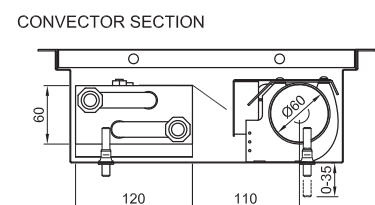
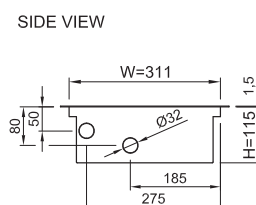
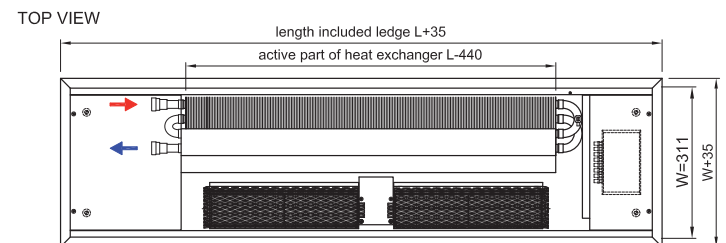
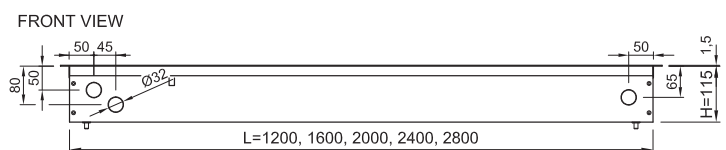



DESCRIPTION

The convector functions as a thermal barrage to keep away the draught from big windows. Lower performance allows covering of large glass walls. Absence of output surplus enables balanced heating of the whole window length. The narrowest convector supporting the window line.



SPECIFICATION

- Detached houses, corridors, halls, passageways
- Narrow convector
- Moderate heating of window areas
- Suitable for combination with other heating systems
- Dry ambience

DIMENSIONS (WITHOUT LEDGE)

- Width: $W = 141$ mm
- Height: $H = 115$ mm
- Length: $L = 1200, 1600, 2000, 2400, 2800$ mm
- Inclusively ledge: $W+35$ mm, $L+35$ mm, $H+1,5$ mm

BASIC INFORMATION

- Paint coated galvanized steel trough
- Lamellar Cu-Al exchanger, connection G1/2", air release valve
- Anodized Al-natur roll grill
- Peripheral ledge 20×20 mm
- Direct and corner lockshield valve packed in

INSTALLATION

Recommended distance from window is 100-150 mm.

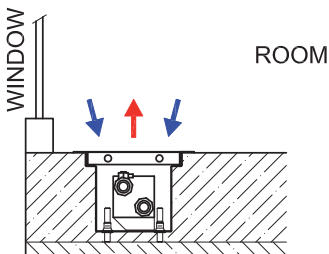

IMPORTANT INFORMATION

- Regulation elements, thermostats, see page 10
- Hydraulic parameters, see page 11
- Lockshield parameters, see page 11

NOTE

No Z-TS230 thermo-drive or Z-TF001 capillary head can be used with FSK20-11 convector type.



HEATING OUTPUT

Temperature gradient	Length [mm] / Output Qn [W]				
	1200	1600	2000	2400	2800
90/70/20 °C	146	213	279	346	413
75/65/20 °C	114	166	218	270	322
70/55/20 °C	91	133	175	216	258
55/45/20 °C	57	83	109	135	161

FRONT VIEW

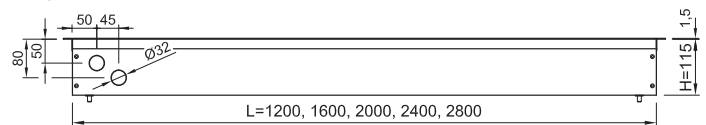

TOP VIEW

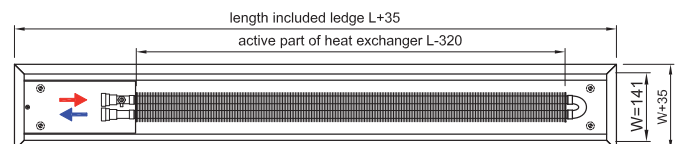

SIDE VIEW

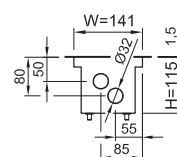

CONVECTOR SECTION

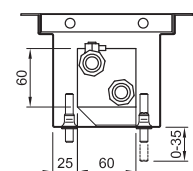



DESCRIPTION

High-performance floor convector, generally used in flats, offices, office buildings, halls etc., mainly in facilities allowing no installation of wiring for fan-fitted convectors.



SPECIFICATION

- Flats, houses offices, corridors, halls ...
- High heating output of natural convection
- Suitable for combining with other heating systems
- Dry ambience

DIMENSIONS (WITHOUT LEDGE)

- Width: W = **311** mm
- Height: H = **115** mm
- Length: L = **1200, 1600, 2000, 2400, 2800** mm
- Inclusively ledge: W +35mm, L+35mm, H+1,5 mm
- Combination with FST40-11, identical width

BASIC INFORMATION

- Paint coated galvanized steel trough
- Lamellar Cu-Al exchanger, connection G1/2", air release valve
- Anodized Al-natur roll grill
- Peripheral ledge 20 × 20 mm
- Direct and corner lockshield valve packed in

INSTALLATION

Recommended distance from window is 100–150 mm.

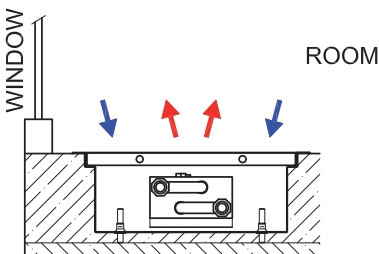

IMPORTANT INFORMATION

- Regulation elements, thermostats, see page 10
- Hydraulic parameters, see page 11
- Lockshield parameters, see page 11



HEATING OUTPUT

Temperature gradient	Length [mm] / Output Qn [W]				
	1200	1600	2000	2400	2800
90/70/20 °C	370	539	707	875	1044
75/65/20 °C	284	414	543	672	802
70/55/20 °C	224	327	429	531	634
55/45/20 °C	136	198	259	321	383

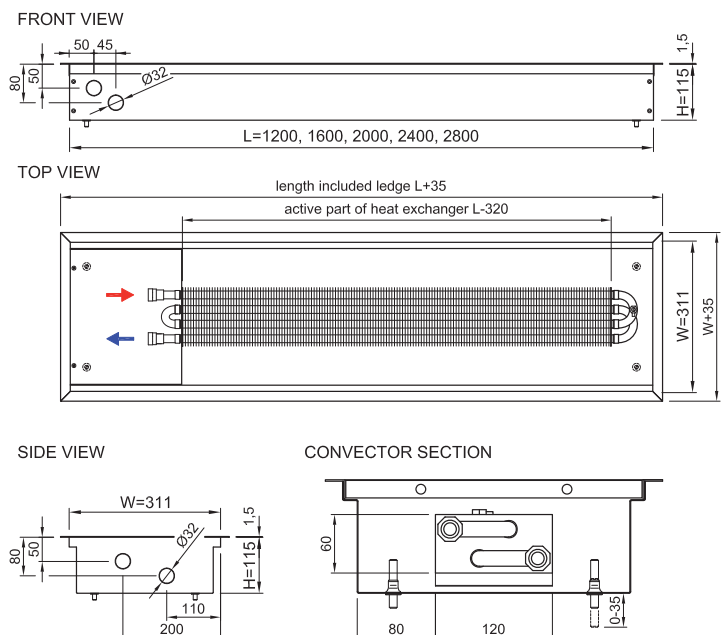



DESCRIPTION

Middle-performance convector without fan. Four-tubes exchanger located in a narrow trough, the width of which is the same as in the FST20-11 type. Combination of convectors with natural and forced convection complies with architects' projects and enables installation of FSK convectors in places showing lower thermal loss.



SPECIFICATION

- Flats, detached houses, offices, corridors
- Good heating output
- Dry ambience

DIMENSIONS (WITHOUT LEDGE)

- Width: $W = 261$ mm
- Height: $H = 115$ mm
- Length: $L = 1200, 1600, 2000, 2400, 2800$ mm
- Inclusively ledge: $W + 35$ mm, $L + 35$ mm, $H + 1,5$ mm
- Combination with FST20-11, identical width

BASIC INFORMATION

- Paint coated galvanized steel trough
- Lamellar Cu-Al exchanger, connection G1/2", air release valve
- Anodized Al-natur roll grill
- Peripheral ledge 20×20 mm
- Direct and corner lockshield valve packed in

INSTALLATION

Recommended distance from window is 100–150 mm.

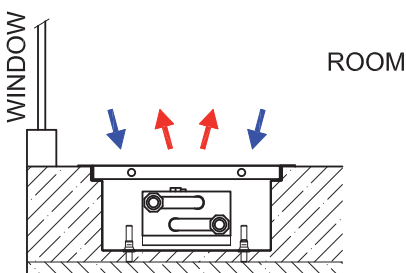

IMPORTANT INFORMATION

- Regulation elements, thermostats, see page 10
- Hydraulic parameters, see page 11
- Lockshield parameters, see page 11



HEATING OUTPUT

Temperature gradient	Length [mm] / Output Qn [W]				
	1200	1600	2000	2400	2800
90/70/20 °C	290	422	554	685	818
75/65/20 °C	223	325	426	527	629
70/55/20 °C	177	257	337	417	498
55/45/20 °C	107	156	204	253	302

FRONT VIEW

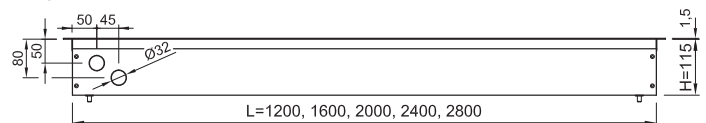

TOP VIEW

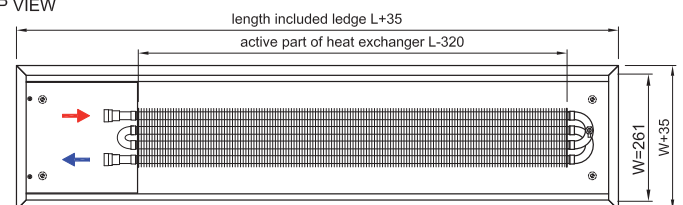

SIDE VIEW

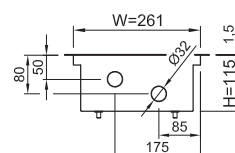

CONVECTOR SECTION

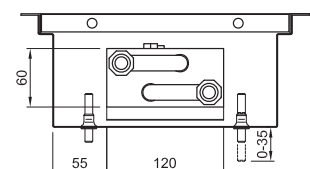

REGULATION OF FST FLOOR CONVECTORS



FST - CABLING EXAMPLE FOR FLOOR CONVECTORS

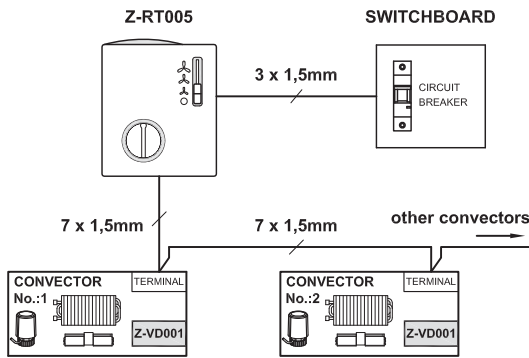

FST INPUT POWER

Length	Input Power
1200mm	65W
1600mm	90W
2000mm	110W
2400mm	110W
2800mm	155W

Length	Motors
1200mm	1pc
1600mm	2pcs
2000mm	2pcs
2400mm	2pcs
2800mm	3pcs

FST - CONNECTION OF OTHER REGULATION PARTS

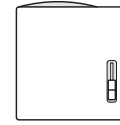

Z-DS002
SIMPLE FAN SPEED SWITCH
ROOM THERMOSTAT
regulates the fan speed within the range of 0, 1, 2, 3 by means of selected slider-switch position

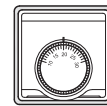
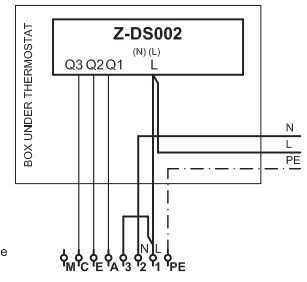

Z-RT001
ROOM THERMOSTAT
switches-on the fans to a chosen speed level according to preset room temperature

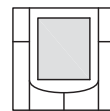
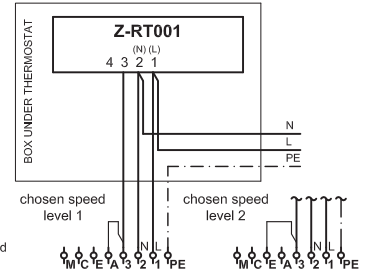

Z-RT006
PROGRAMMABLE THERMOSTAT WITH LCD
manually or automatically switches-on/off the convectors as per the preset thermostat modes within the fan speed range of 0, 1, 2, 3

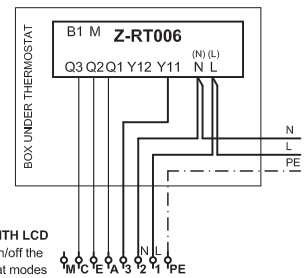

- THE SAFETY OF DULY EARTHED CONVECTORS IS VERIFIED AND PROVED BY STROJÍRENSKÝ ZKUŠEBNÍ ÚSTAV (ENGINEERING CONDITIONING HOUSE), BRNO, A NOTIFIED AND AUTHORISED BODY UNDER THE REGISTRATION Nos. ES 1015 / 202.
- A RESIDUAL CURRENT DEVICE SHOULD PROTECT THE ELECTRIC PART
- THE ELECTRIC INSTALLATION HAS TO BE DONE BY QUALIFIED PERSONS ONLY
- THE INSTALLATION OF ALL ELECTRIC DEVICES MUST COMPLY WITH PROVISIONS OF NATIONAL STANDARDS

FST - WIRING DIAGRAM OF FLOOR CONVECTORS

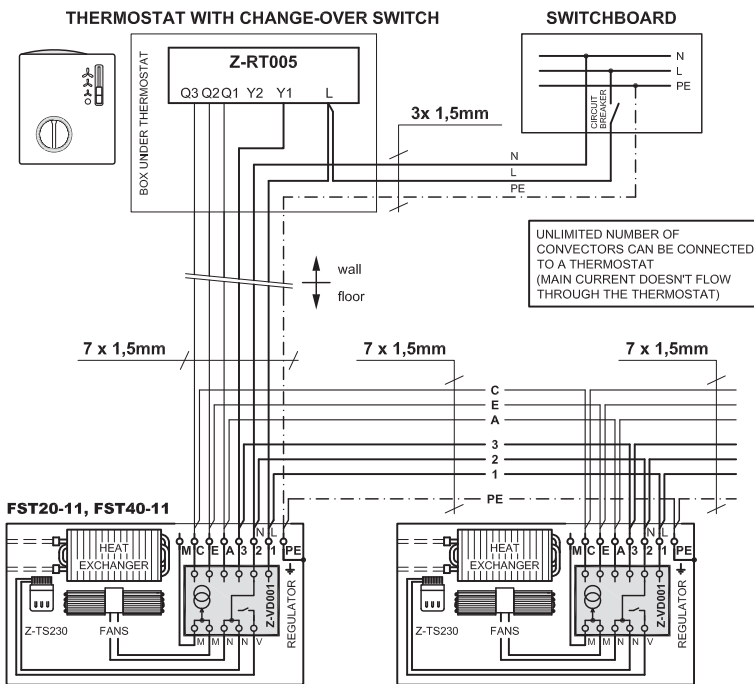

Z-VD001 REGULATOR IS A PART OF EACH CONVECTOR, Z-TS230 THERMOACTUATOR IS AVAILABLE AS ACCESSORY

REGULATION OF FSK FLOOR CONVECTORS



FSK - CABLING EXAMPLE FOR FLOOR CONVECTOR WITH Z-TS230

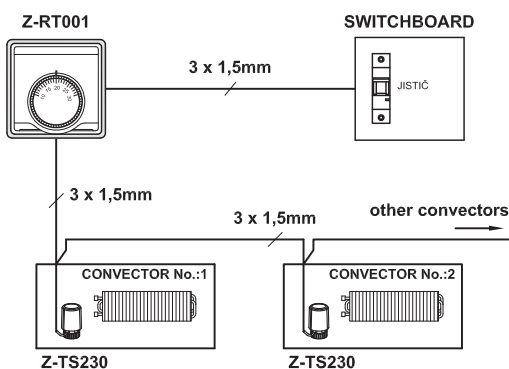

FSK - CONNECTING WITH CAPILLARY THERMOSTAT Z-TF001

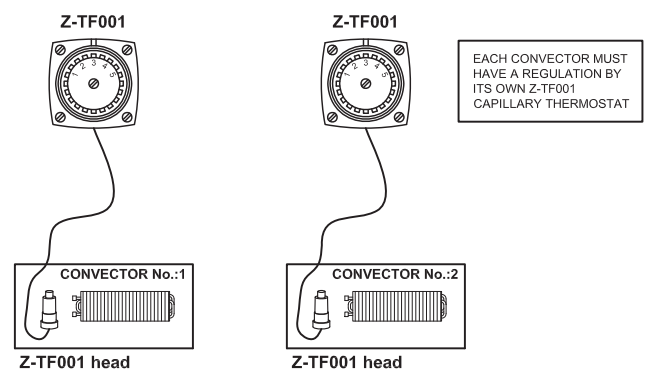



THERMOSTATS

Z-DS002 | Simple fan speed switch

Switch levels:	0, 1, 2, 3
Operating voltage:	230V/50Hz
Max. switched current:	6 (2) A
Degree of protection:	IP30
Colour:	white
Dimension:	96 × 97 × 36 mm



Z-RT001 | Room thermostat

Temperature range:	10 až 30 °C
Operating voltage:	230V/50Hz
Max. switched current:	10 (3) A
Degree of protection:	IP30
Colour:	white
Dimension:	83 × 83 × 40 mm



Z-RT005 | Manual room thermostat with speed switch

Temperature range:	8 to 30 °C
Switch levels:	0, 1, 2, 3
Operating voltage:	230V/50Hz
Max. switched current:	6 (2) A
Degree of protection:	IP30
Colour:	white
Dimension:	96 × 110 × 36 mm



Z-RT006 | Heating, cooling

Room thermostat with backlit LCD, 7-day time program, 8 programmable timers, manual or automatic speed switching, mode heating/cooling for 2-pipe and 4-pipe floor convectors

Temperature range:	0-49 °C
Modes:	Comfort, Economy, Protection
Speeds:	1,2,3 or automatic
Operating voltage:	230V / 50Hz
Power consumption:	max. 8VA
Outputs rating:	5 (2)A
Protection:	IP30
Colour:	RAL9003 white
Dimension:	87 × 87 × 58 mm



For installation is needed to use rectangle conduit box for semi-flush mounted thermostat ARG71, delivered as a part of thermostat

FLOW REGULATION

Z-TS230 | Thermoelectric actuator for thermostat valve control

Mode:	open/closed (ON/OFF)
Operating voltage:	230V/50Hz
Degree of protection:	IP44
Medium temperature:	max: 120 °C
Body-head connection:	M30 × 1,5 mm
Colour:	white
Dimension:	∅ 45 × 63 mm



Z-TF001 (available for FSK only) | Radiator thermostat with remote setting

Temperature range:	9 to 26 °C, antifreeze temperature 9 °C
Mode:	proportional control
Operating temperature:	without additional energy, liquid-filled sensing
capillara tube length:	5 m
Body-head connection:	M30 × 1,5 mm
Dimension:	75 × 75 mm, sensor ∅ 50 × 68 mm



THERMOSTATIC VALVES

Z-TD001 / Z-TE001 | Thermostat. valve direct / corner

DN15, NF norm, M30 × 1,5 mm, PN10, 120 °C

Valve adjusting	1	2	3	4	5	N
k_v (m³/h)	0,1	0,2	0,31	0,45	0,69	0,89



HYDRAULIC RESISTANCE OF HEAT EXCHANGERS

Type	Length [mm]	Volume [l]	Qv – Mass flow [kg/h] / R - Hydraulic resistance of heat exchangers [kPa]												
			20	40	60	80	100	120	150	200	250	300	350	400	450
FST20-11 FSK20-11	1200	0,27	0,01	0,02	0,06	0,09	0,14	0,20	0,30	0,52	0,81	1,13	1,52	1,98	2,46
	1600	0,39	0,01	0,03	0,07	0,12	0,17	0,25	0,37	0,65	0,99	1,38	1,86	2,41	3,00
	2000	0,52	0,01	0,03	0,09	0,14	0,21	0,30	0,45	0,77	1,18	1,63	2,20	2,84	3,53
	2400	0,64	0,01	0,04	0,10	0,16	0,24	0,35	0,52	0,89	1,36	1,89	2,54	3,28	4,06
	2800	0,76	0,01	0,05	0,11	0,19	0,28	0,40	0,59	1,01	1,55	2,14	2,87	3,71	4,59
FST40-11 FSK40-11 FSK41-11	1200	0,54	0,01	0,05	0,13	0,21	0,32	0,46	0,69	1,21	1,86	2,62	3,54	4,59	5,74
	1600	0,79	0,02	0,06	0,15	0,26	0,39	0,56	0,84	1,45	2,23	3,12	4,21	5,46	6,80
	2000	1,03	0,02	0,07	0,18	0,31	0,45	0,66	0,98	1,70	2,60	3,63	4,89	6,33	7,86
	2400	1,28	0,02	0,09	0,21	0,35	0,52	0,76	1,13	1,94	2,97	4,13	5,56	7,20	8,93
	2800	1,53	0,03	0,10	0,24	0,40	0,59	0,86	1,27	2,19	3,34	4,63	6,23	8,06	9,99

LOCKSHIELDS PARAMETERS

T - turns	0,5	0,75	1	1,5	2	2,5	3	3,5	4	5	6	MAX
K_v (m ³ /h) – direct version	0,3	0,4	0,55	0,75	0,91	1,05	1,25	1,33	1,4	1,6	1,7	1,8
K_v (m ³ /h) – corner version	0,2	0,25	0,29	0,4	0,5	0,69	0,8	1	1,2	1,55	1,9	2,2

parameters of packed in lockshield valves

PRACTIC TEMPERATURE EXPONENTS

Type	exponent m	
	without fan	with fan
FST20-11	1,36	1,08
FST40-11	1,44	1,01
FSK20-11	1,37	-
FSK40-11	1,45	-
FSK41-11	1,44	-

m – temperature exponent for recalculation to other temperature gradient



ISAN RADIÁTORY S.R.O.
Poříčí 26, 678 33 Blansko
CZECH REPUBLIC
TEL.: +420 516 489 180
FAX: +420 516 489 605
E-MAIL: SALES@ISAN.CZ
WWW.ISAN.CZ

ISAN PRODUCT LINES

FLOOR CONVECTORS
TERMO

BATHROOM AND DESIGN RADIATORS
MELODY

CONVECTORS AND LAMELLAR RADIATORS
EXACT

TUBULAR RADIATORS
ATOL

FINNED TUBE RADIATORS
SPIRAL