

Kamin / Kamin-ER

Chimney centrifugal fans

Use

- For arranging warm air distribution system from chimney room to other rooms.
- For heating of occasionally or seasonally occupied buildings.
- Operating temperature from 0 to 150 °C.
- Compatible with Ø 125 up to 160 mm round air ducts.



Air flow:
up to 613 m³/h
170 l/s



Power:
from 32 W



Noise level:
from 37 dBA



Design

- Atmospheric resistant galvanized steel casing and impeller.
- Thermal and heat-insulation with non-flammable mineral wool.
- The casing is perforated for internal air circulation for cooling the motor down.
- The casing has fixing for connection of extra options (filter, mixing chamber, bypass system).
- Power is supplied to the fan through an external terminal box with sealed electric lead-in.
- Switches on and off at set temperatures. Regulation by built-in temperature regulator.



Motor

- Single-phase asynchronous motor. Centrifugal impeller with forward curved blades.
- The Kamin-ER fan is equipped with an external rotor motor.
- The motor is placed off the air flow and is equipped with extra axial impeller for motor cooling and blowing off.
- Motor insulation class F.
- Equipped with ball bearings for longer service life.
- Dynamically balanced impeller.
- Overheating protection by built-in thermal switches with automatic restart.

Speed control

- Smooth speed control with an external thyristor controller or step speed control with an external auto transformer (both available upon separate order).

Mounting

- Suitable for installation in any mounting position with respect to air flow direction in the system.
- Warm air distribution from the fan to other premises through the mounted air ducts.

Options

AF: metal filter-box for air purification. Filter class G3.



KF: metal mixing chamber for cold air supply. The chamber includes a temperature regulating damper and filter for air purification. The chamber provides cold air supply when the air temperature exceeds 90 °C and hot air removal when the fan is off.



GF: gravity damper to prevent air back draft in the system. Together with the KF mixing chamber provides motor overheating protection (BYPASS system). When the motor is not running (e.g. during power cut-off), the gravity damper is closed and warm air is distributed through the mixing chamber and connected air ducts to other rooms.

If the transported air temperature is too high (exceeds +120 °C), the BYPASS system stabilizes the temperature by opening the damper of the mixing chamber and by cold air supply.

Designation key

Series	Modification	Duct diameter	Motor modification	Options
Kamin	_: standard -ER: external rotor motor	125; 150; 160	_: standard max: high-powered motor	US: speed switch AF: metal filter-box KF: metal mixing chamber GF: gravity damper

Accessories

Filter box	Filter	Mixing chamber	Gravity damper	Clamp
				
AF	FP-AF	KF	GF	K

OPERATING LOGIC OF THE FAN KAMIN WITH AF FILTER-BOX

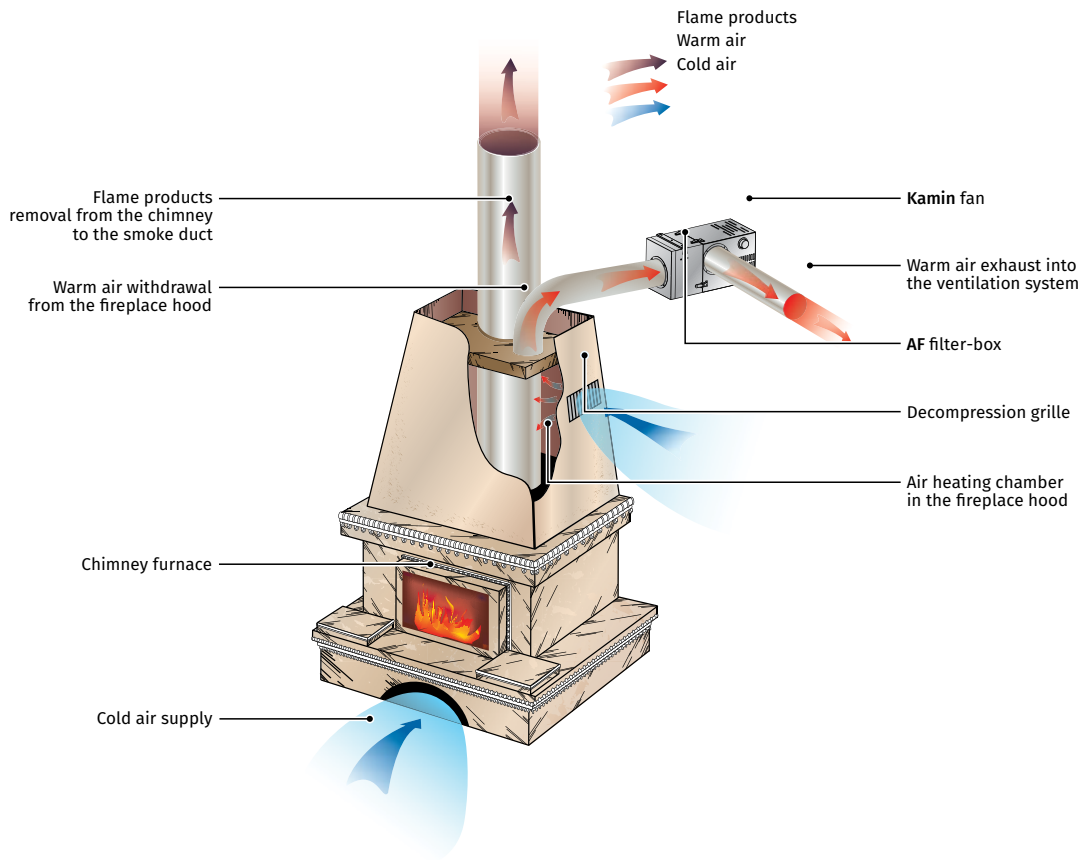

OPERATING LOGIC OF THE FAN KAMIN WITH BY-PASS SYSTEM

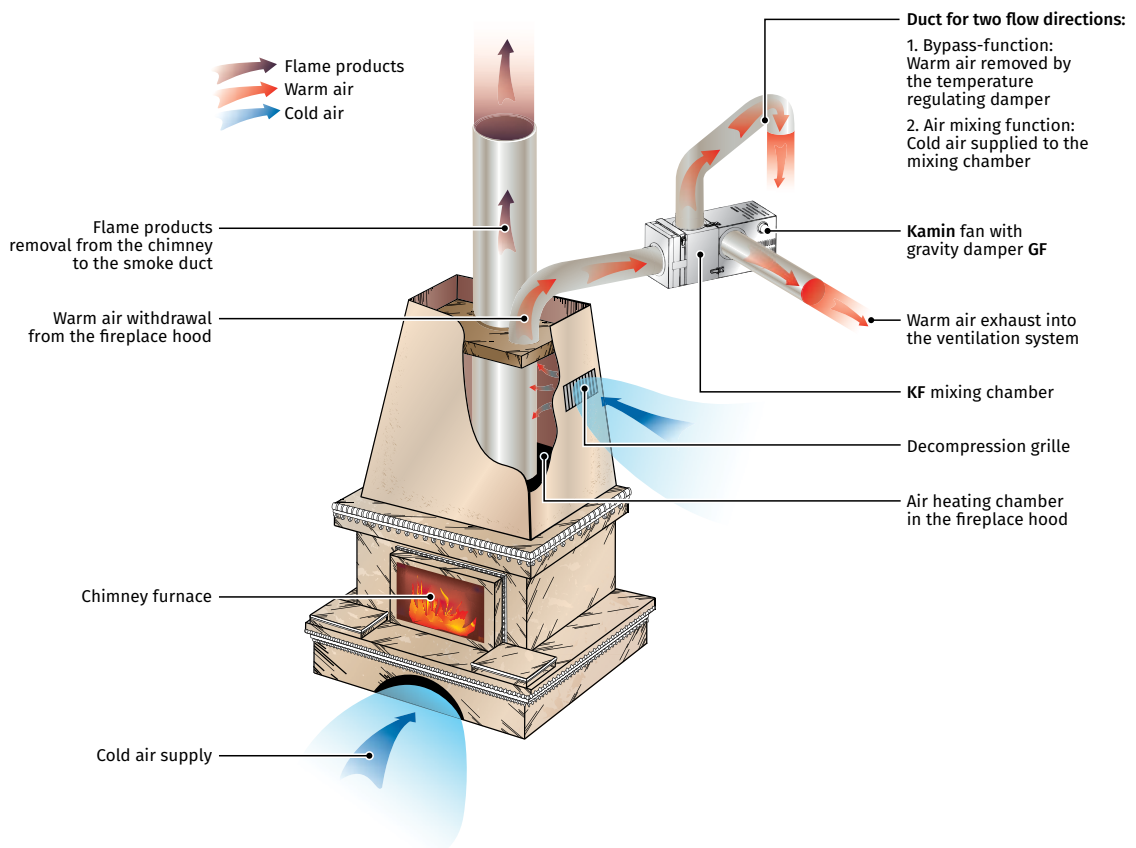

Technical data

Parameters	Kamin 125	Kamin 150	Kamin 160
Voltage [V]	1 ~ 230	1 ~ 230	1 ~ 230
Frequency [Hz]	50	50	50
Power [W]	108	115	116
Current [A]	0.81	0.84	0.86
Maximum air flow [m ³ /h (l/s)]	400 (111)	520 (144)	540 (150)
RPM [min ⁻¹]	1300	1280	1270
Sound pressure at 3 m [dBA]	42	42	42
Max. transported air temperature [°C]	+150	+150	+150
SEC class	-	-	-
IP rating	IPX2	IPX2	IPX2
Motor IP rating	IP42	IP42	IP42

Parameters	Kamin-ER 125	Kamin-ER 150	Kamin-ER 150 max	Kamin-ER 160
Voltage [V]	1 ~ 230	1 ~ 230	1 ~ 230	1 ~ 230
Frequency [Hz]	50	50	50	50
Power [W]	32	43	115	44
Current [A]	0.14	0.19	0.51	0.19
Maximum air flow [m ³ /h (l/s)]	350 (97)	450 (125)	613 (170)	470 (131)
RPM [min ⁻¹]	1335	1165	1296	1110
Sound pressure at 3 m [dBA]	37	39	45	39
Max. transported air temperature [°C]	+150	+150	+150	+150
SEC class	-	-	-	-
IP rating	IPX2	IPX2	IPX2	IPX2
Motor IP rating	IP42	IP42	IP42	IP42

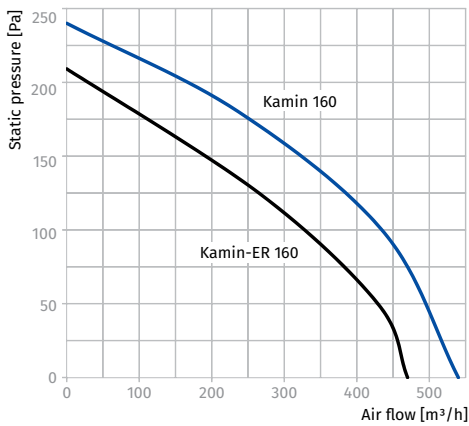
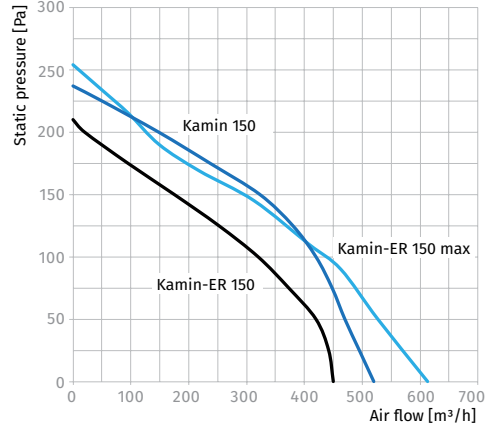
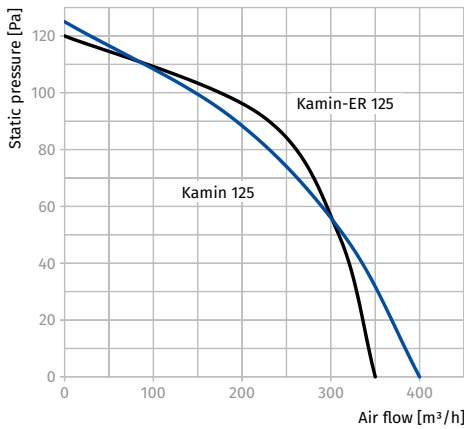

CHIMNEY FANS

Overall dimensions [mm]

KAMIN / KAMIN-ER SERIES FANS

Type	Ø D	B	H	H1	L	P	Weight [kg]
Kamin 125	124	245	350	300	260	50	4.5
Kamin 150	149	285	350	300	300	50	5.7
Kamin 160	159	285	350	300	300	50	5.7
Kamin-ER 125	124	245	320	270	260	50	5.6
Kamin-ER 150	149	285	320	270	300	50	6.8
Kamin-ER 150 max	149	285	320	270	300	50	6.8
Kamin-ER 160	159	285	320	270	300	50	6.8

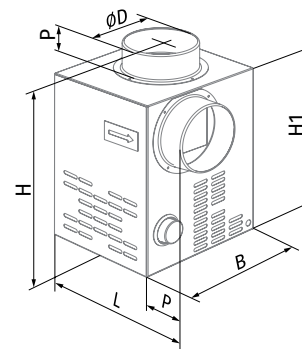

KAMIN / KAMIN-ER SERIES FANS EQUIPPED WITH FILTER BOX AF

Type	Extra option	Ø D	B	H	H1	L	P	Weight [kg]
Kamin 125	AF 125	124	245	530	480	260	50	6.7
Kamin 150	AF 150	149	285	540	490	300	50	8.7
Kamin 160	AF 160	159	285	540	490	300	50	8.7
Kamin-ER 125	AF 125	124	245	500	450	260	50	7.8
Kamin-ER 150	AF 150	149	285	510	460	300	50	9.8
Kamin-ER 150 max	AF 150	149	285	510	460	300	50	9.8
Kamin-ER 160	AF 160	159	285	510	460	300	50	9.8

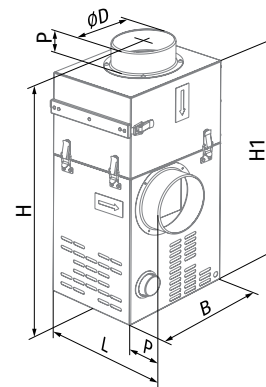

KAMIN / KAMIN-ER SERIES FANS EQUIPPED WITH MIXING CHAMBER KF AND DAMPER GF

Type	Extra option	Ø D	B	H	H1	L	P	Weight [kg]
Kamin 125	KF 125 / KF 125 + GF 125 (BYPASS)	124	245	610	560	260	50	8.3
Kamin 150	KF 150 / KF 150 + GF 150 (BYPASS)	149	285	650	600	300	50	9.7
Kamin 160	KF 160 / KF 160 + GF 160 (BYPASS)	159	285	650	600	300	50	9.7
Kamin-ER 125	KF 125 / KF 125 + GF 125 (BYPASS)	124	245	580	530	260	50	9.4
Kamin-ER 150	KF 150 / KF 150 + GF 150 (BYPASS)	149	285	620	570	300	50	10.8
Kamin-ER 150 max	KF 150 / KF 150 + GF 150 (BYPASS)	149	285	620	570	300	50	10.8
Kamin-ER 160	KF 160 / KF 160 + GF 160 (BYPASS)	159	285	620	570	300	50	10.8

